

LGMG

H1256

TELEHANDLER



LGMG TELEHANDLER

SPECIFICATIONS

MODELS	H1256	
Measurements	Imperial	Metric
A Max. Lifting Height	56'1"	17.1 m
Max. Outreach	42'	12.8 m
B Overall Length	21'7"	6.57 m
C Overall Width	7'11"	2.41 m
D Overall Height	8'10"	2.7 m
E Wheelbase	11'6"	3.5 m
Ground Clearance	1'4"	0.4 m
PRODUCTIVITY		
Max. Capacity	12,000 lbs	5,443 kg
Gradeability-Unladen	50%	
Min. Turning Radius	<14'1"	<4.3 m
Tilt Angle	±10°	
Drive / Steering Mode	4 Wheel Drive / 4 Wheel Steer	
Primary Boom Ascending Time	15-25 s	
Primary Boom Descending Time	10-20 s	
Boom Extending Time	20-30 s	
Boom Retracting Time	15-25 s	
Forward - First Gear Travel Speed	3.1 mph	5 km/h
Forward - Second Gear Travel Speed	5.6 mph	9 km/h
Forward - Third Gear Travel Speed	11.8 mph	19 km/h
Forward - Fourth Gear Travel Speed	15.5 mph	25 km/h
Backward - First Gear Travel Speed	3.1 mph	5 km/h
Backward - Second Gear Travel Speed	5.6 mph	9 km/h
Backward - Third Gear Travel Speed	11.8 mph	19 km/h
Braking	Multi-disc wet brake	
Tire Type	Foam-filled tires	
Tire Models	400/75-28	
ENGINE		
Manufacturer	Cummins	
Rated Power	120.7 hp	90 kW
Max. Torque	368.8 lb.ft	500 N.m
Displacement	231.9 cu.in	3,800 ml
Fuel Tank Capacity	38.3 gal	145 L
HYDRAULIC SYSTEM		
Working pump displacement	63 ml/r	
Hydraulic Oil Capacity	37.5 gal	142 L
WEIGHT		
Machine Weight	34,833 lbs	15,800 kg

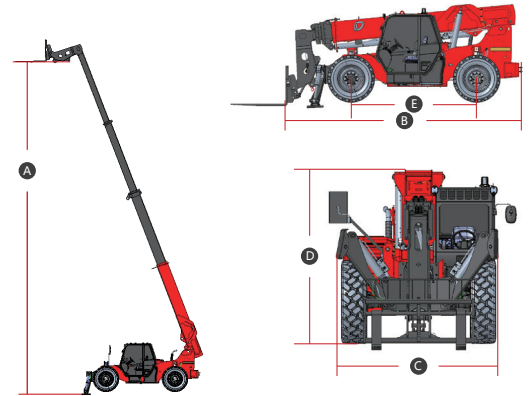

ROUGH TERRAIN LOAD CHART

Hydraulic Outriggers Not Open

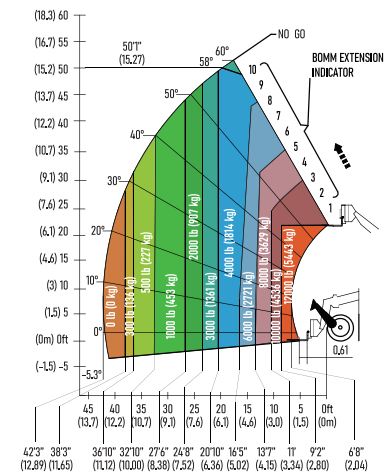

ROUGH TERRAIN LOAD CHART

Hydraulic Outriggers Fully Open

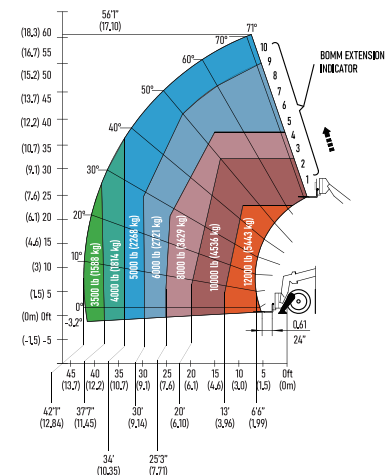

Please contact LGMG or a local dealer for more details.

LGMG reserves the right to change technical data without prior notice. All photos and pictures in this brochure are for promotional purposes only.

LGMG North America Inc.

Address: 1445 Sheffler Dr, Chambersburg, PA. 17201, USA

Email: sales@lmgna.com Tel: +1 833 288 5464

www.lmgglifts.com



RELIABILITY IN ACTION